



cut



PO Box 31397
 BELLINGHAM, WA 982
 (T) 360-752-1610 • 888-8
 (F) 360-752-1612 • 888-8

**CEDARWOOD SERIES
 - SINGLE STEM MOUNTING**

HW KIT # 94-Hs

PARTS LIST - SECTION B

- A. Ring for Pivoting Hanger
- B. 1/2" Diameter x 12" pipe (same pipe from Section A)
- C. Pivoting Hanger
- D. Ceiling Canopy
- E. Cross Bar
- F. Wire Connectors (2)
- G. 1" Machine Screws (2)
- H. Threaded Pipe

SECTION B - MOUNTING TO FLAT CEILING

1. Place the cross bar (E) on the junction box and secure with the machine screws (G).
2. Wrap the green ground wire and the bare copper wire around the green ground screw in a clockwise direction and secure.
3. Thread the threaded pipe (H) into the cross bar (E) so that the pipe extends about 1" from the bottom.
4. Feed the fixture wires through the ring for pivoting hanger (A) and slip the ring towards the fixture.
5. Feed fixture wires through the big hole in the ceiling canopy (D) and slip towards the fixture.
6. Attach the pivot hanger (C) to the top of the pipe (B) with the outer threads away for the fixture.
7. Feed the wires through the threaded pipe (H) in the cross bar (E).
7. Unscrew the metal clutch piece so the 1/2" pipe spins free.
8. Lift the entire fixture up to the junction box. Feed the brown fixture wire and bare copper ground wire through the pivot hanger. Secure by spinning the 1/2" pipe in a counter clockwise direction. Once secure, reattach the metal clutch pieces to the pipe.
9. Using the wire connectors (F), connect the white supply wire to the ridged fixture wire and connect the black supply wire to round fixture wire. Be sure no bare wires are exposed outside of wire connectors. Tuck extra wires back into the ceiling outlet box.
10. Now raise the ceiling canopy (D) to the junction box and secure with the ring for pivoting hanger (A).
11. Install the glass by unscrewing the white retaining ring located on the socket, raise the glass over the socket and fit into the glass holder, and secure with the white retaining ring. (Note: It may be necessary to rotate the glass slightly together with the retaining ring to get a secure fit).
12. Now electricity can be restored to the fixture.

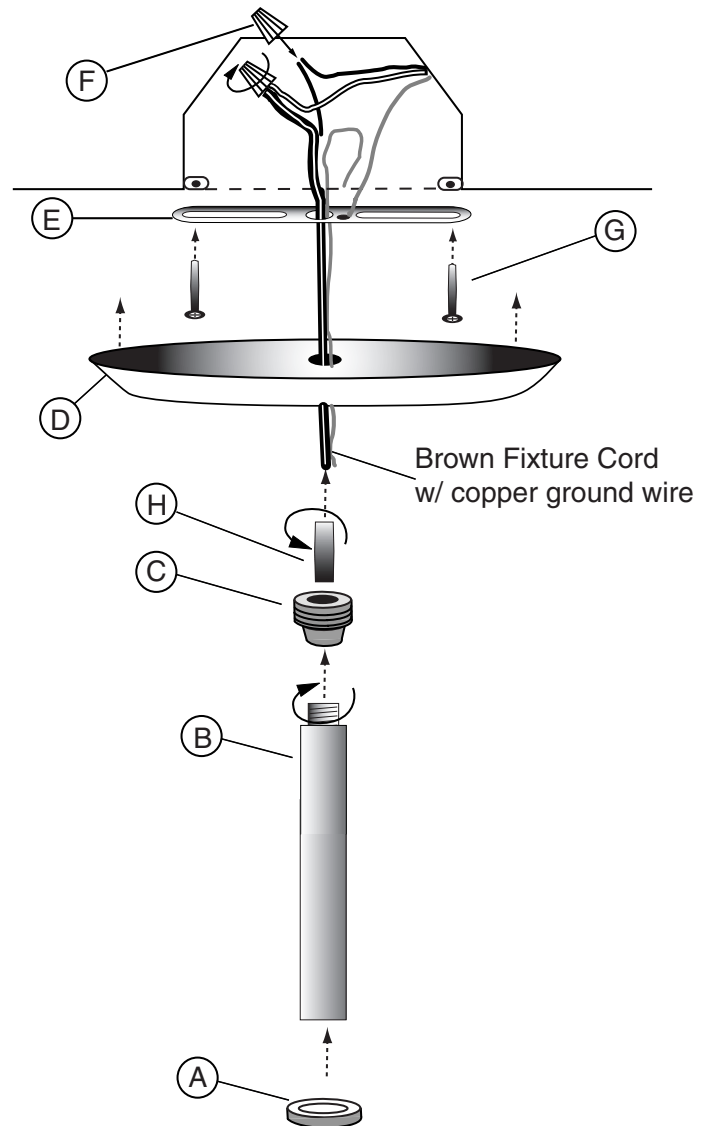

LIMITED 2-YEAR WARRANTY: Cedar Valley Lighting warrants that its products are free of defects in workmanship and materials for a period of two years from date of purchase. If within two years from date of purchase any of its products are found defective in workmanship or materials, Cedar Valley Lighting will repair or replace, at its sole option, the defective product upon presentation of proof of purchase and the defective product.

THIS WARRANTY IS IN LIEU OF ALL OTHER WARRANTIES INCLUDING, WITHOUT LIMITATION, ANY IMPLIED WARRANTIES OF MERCHANTABILITY OR FITNESS FOR A PARTICULAR PURPOSE. Cedar Valley Lighting's liability under any warranty, whether express or implied, is LIMITED SOLELY TO THE REPAIR OR REPLACEMENT OF THE DEFECTIVE PRODUCT FOR THE DURATION OF THIS WARRANTY AND DOES NOT INCLUDE LABOR OR OTHER CONSEQUENTIAL OR INCIDENTAL DAMAGES.