

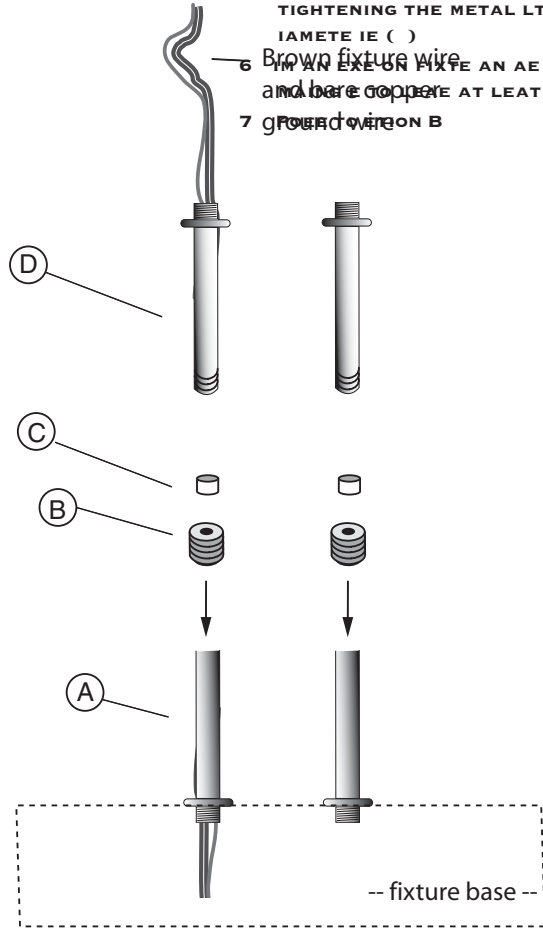

PO Box 31397  
 BELLINGHAM, WA 98228-3517  
 (T) 360-752-1610 • 888-841-1810  
 (F) 360-752-1612 • 888-841-1812  
 WE NEED TO SEE THE ORIGINAL FIXTURE AND A PHOTO OF THE LOCATION TO DETERMINE THE BEST WAY TO INSTALL IT.

2. SEE THE INSTRUCTIONS THROUGH THE METAL LATH (B) AND LABELS ON THE END OF THE 3/8" INCH METAL LATH, MAKING SURE THE METAL LATH IS PLACED OVER THE OTHER METAL LATH ON THE OTHER SIDE.
3. SEE THE INSTRUCTIONS THROUGH THE LATH (C) AND LABELS ON THE END OF THE 3/8" INCH METAL LATH. PLACE THE OTHER LATH OVER THE OTHER LATH ON THE OTHER SIDE.
4. SEE THE INSTRUCTIONS THROUGH THE METAL LATH (D) AND THEN LABELS ON THE END OF THE 3/8" INCH METAL LATH, MAKING SURE THE METAL LATH IS PLACED OVER THE OTHER METAL LATH ON THE OTHER SIDE.
5. CUT IT TO THE CORRECT LENGTH OF THE FIXTURE BY TIGHTENING THE METAL LATH ONTO THE OTHER END OF THE METAL LATH (E).
6. STRIP THE INSULATION FROM THE BROWN AND BLUE WIRES AT LEAST 8" OF THE LENGTH OF THE WIRE.
7. STRIP THE INSULATION FROM THE GREEN GROUND WIRE AT LEAST 8" OF THE LENGTH OF THE WIRE.

**DIAGRAM 1**

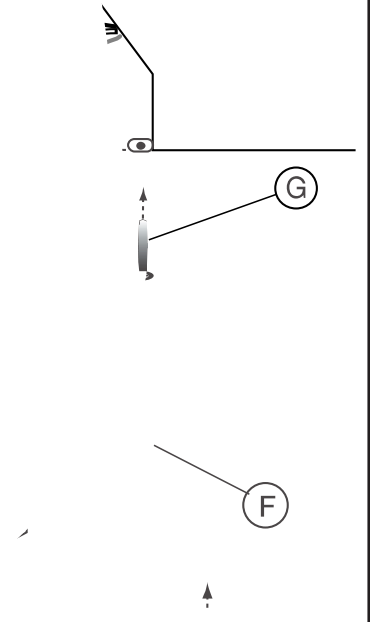

**DIAGRAM 2**



**DARWOOD SERIES  
STEM MOUNTING**

**HW KIT # 94-H434**



(A)

THIS WARRANTY IS IN LIEU OF ALL OTHER WARRANTIES, INCLUDING BUT NOT LIMITED TO, ANY IMPLIED WARRANTIES OF MERCHANTABILITY AND FITNESS FOR A PARTICULAR PURPOSE. Cedar Valley Light Fixtures, Inc. and its subsidiaries, express or implied, is LIMITED SOLELY TO THE ORIGINAL PRODUCT FOR THE DURATION OF THE WARRANTY PERIOD OR OTHER CONSEQUENTIAL DAMAGES.